

ISSUES

No.	DESCRIPTION	DATE
1	ISSUED FOR RE-ZONING/OPA	2020-08-31
2	ISSUED FOR RE-ZONING/OPA	2022-04-08

PROPOSED PARKING BLDG. A

Level	Count
SURFACE PARKING	43
LEVEL 1 GROUND FLOOR	5
LEVEL P1	79
A-R	127
A-V	21
TOTAL	148

BUILDING A (127 UNITS) :
 127 RESIDENTIAL @ PROPOSED RATIO: 1.0 / UNIT
 21 VISITORS @ PROPOSED RATIO: 0.15 / UNIT

PROPOSED PARKING BLDG. B

Level	Count
SURFACE PARKING	44
LEVEL 1 GROUND FLOOR	6
LEVEL P1	76
B-R	126
B-V	20
TOTAL	146

BUILDING B (126 UNITS) :
 126 RESIDENTIAL @ PROPOSED RATIO: 1.0 / UNIT
 20 VISITORS @ PROPOSED RATIO: 0.15 / UNIT

PROPOSED PARKING BLDG. C

Level	Count
LEVEL 04	64
LEVEL 03	65
LEVEL 02	65
SURFACE PARKING	12
LEVEL 1 GROUND FLOOR	49
C-R	255
C-V	40
TOTAL	295

BUILDING C (255 UNITS) :
 255 RESIDENTIAL @ PROPOSED RATIO: 1.0 / UNIT
 40 VISITORS @ PROPOSED RATIO: 0.15 / UNIT

PROPOSED PARKING TOTAL BY LEVEL

Level	Count
LEVEL 04	64
LEVEL 03	65
LEVEL 02	65
SURFACE PARKING	180
LEVEL 1 GROUND FLOOR	60
LEVEL P1	155
TOTAL: 589	589

SITE TOTAL (508 UNITS)
 508 RESIDENTIAL @ PROPOSED RATIO: 1.0 / UNIT
 81 VISITORS @ PROPOSED RATIO: 0.15 / UNIT
 SITE TOTAL PARKING SPACES : 589

LEGEND - PARKING SPACE DIMENSIONS

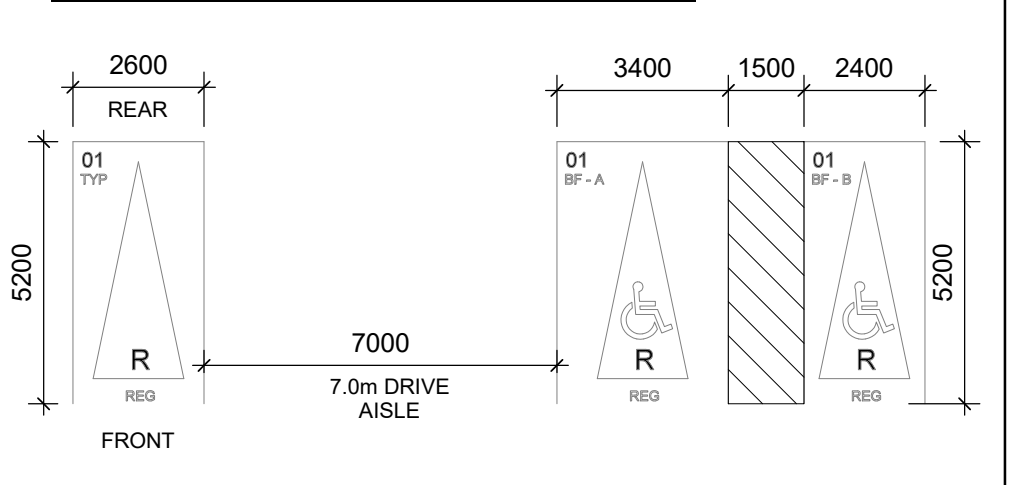

LEGEND - PARKING SYMBOLS & NOTATIONS

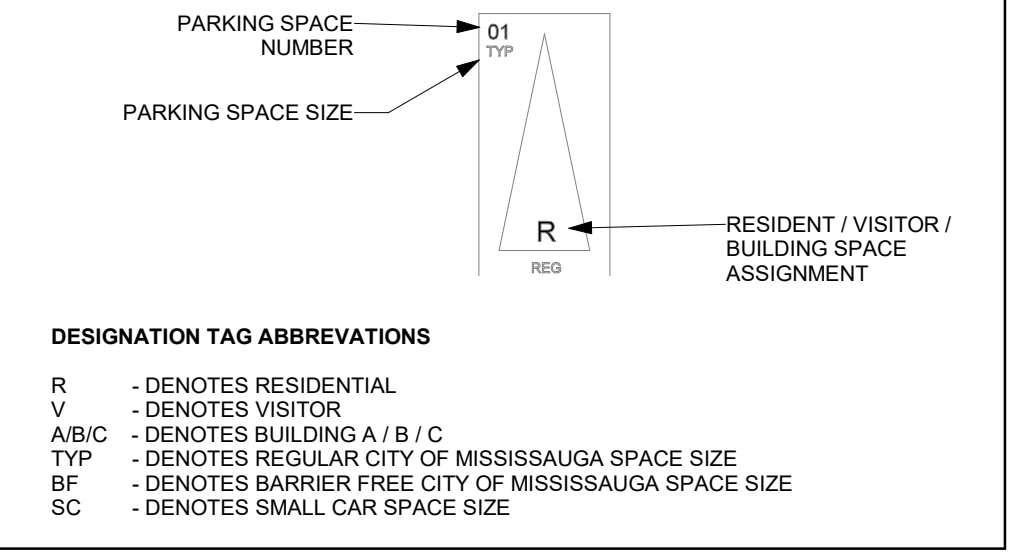

TOTAL RESIDENTIAL BIKE...

Level	Total Bike Spaces	RES LT		RES ST	
		Long Term Residential	Short Term Residential	Long Term Residential	Short Term Residential
LEVEL P1	121	121	0		
LEVEL 1 GROUND FLOOR	69	29	40		
LEVEL 02	12	12	0		
LEVEL 03	11	11	0		
LEVEL 04	9	9	0		
TOTAL BIKE SPACES	222	182	40		

BUILDING C (255 UNITS)
 178 LONG TERM BIKES @ REQUIRED RATIO: 0.7 / UNIT
 20 SHORT TERM BIKES @ REQUIRED RATIO: 0.08 / UNIT

BUILDING A+B (253 UNITS)
 20 SHORT TERM BIKES @ REQUIRED RATIO: 0.08 / UNIT

