

- NOTES:**
- All dimensions are in millimetres unless otherwise noted. This detail to be used in conjunction with pertinent specification.
 - Remove stakes and wires by second growing season or end of warranty period.
 - This detail is based on 800mm O.C. street tree spacing. Dimensions appropriate to reach goal of 25 cubic metres of soil volume per tree.
 - Prune only dead, damaged or interfering branches. Leaders are not to be cut.
 - Tree pit to be excavated as per specifications. Depth of planting pit to be approved by Community Services representative.
 - Backfill with planting soil mix in accordance with specifications and approved planting plan.
 - Soil volume specifications based on loam soil, good drainage and no added irrigation.
 - All planting shall be done under the direction and supervision of personnel with at least 5 years horticultural and planting experience and conform to best horticultural practices. Planting of plant material prior to Community Services approval will be at the contractors risk.
 - Samples of mulch, top soil and tree accessories must be submitted to Community Services for approval.
 - Plants shall be sound, healthy, vigorous and well branched. They shall be free of insect beetle eggs and larvae and shall have healthy well developed root systems. Community Services reserves the right to reject plant material that does not conform to planting plan specifications.
 - Keep all plants watered from time of planting until acceptance.

Detail: 02950-17 ORIGINAL DATE: Oct 09/15 REVISION DATE: month xx/1x MISSISSAUGA

DECIDUOUS TREE PLANTING

Not to Scale

Topsoil Placement & Fine Grading

- Ensure that the approval has been obtained for rough grading prior to proceeding with this section of work.
- Scarify the rough graded areas to provide a loosened surface in order to allow bonding of the topsoil.
- Spread topsoil on the prepared and accepted rough graded surface to a minimum depth of 450 mm firmly packed.
- Keep topsoil 25 mm below finished grade for sodded areas elsewhere bring topsoil up to finished grade of adjacent surfaces.
- The finished surface is to be smooth and even with no ruts, clods or contaminants.
- Remove stones in excess of 10mm for area to be seeded.
- Hand rake areas to be seeded or sodded as a final surface preparation coordinating the work to ensure that seeding or sodding can occur as soon as possible after raking has been completed.

Sodding

- Schedule deliveries in order to keep storage at job site to a minimum without causing delays.
- Sod shall be certified #1 Nursery Grown sod containing 50% merion blue grass and 50% Kentucky blue grass. It shall be no greater than 40mm (1-1/2") in thickness and with accordance with the classification of turf grass sod for the province by the national sod growers association.
- Obtain approval of topsoil grade and depth before starting sodding. Areas to be smooth graded by a landscape grader and hand raked to provide a completely smooth and even surface.
- Lay sod in rows, perpendicular to slope, smooth and even with adjoining areas and with joints staggered. Butt sections closely without overlapping or leaving gaps between sections. Cut out irregular or thin sections with a sharp knife.
- Stake all sod on slopes greater than 1:5 (20%).
- Roll sod immediately after laying to press sod firmly on to the surface soil.
- Water immediately after sod laying to obtain moisture penetration through sod into top 100mm (4") of topsoil. Water by means of a water truck or if approved, by hydrant to obtain a complete drenching. Watering by small hose and sprinkler is not sufficient. For the first 30 days, soak to this depth at least once a week.
- Water in similar manner thereafter if sufficient rain does not fall, in order to keep the underlying surface moist. Watering until acceptance of the sod is the contractors responsibility.
- Immediately clean up soil or debris spilled onto pavement and dispose of deleterious materials.
- Sodded areas will be accepted and warranty period begins provided that:
 - Sod is completely green
 - Sodded areas have been cut minimum of two times
 - Sod is knit to underlying soil and cannot be lifted when tugged by hand.
- It is the contractors responsibility to maintain sod until time of sod acceptance. Maintenance of sod after acceptance is the responsibility of owner.

Planting Specifications

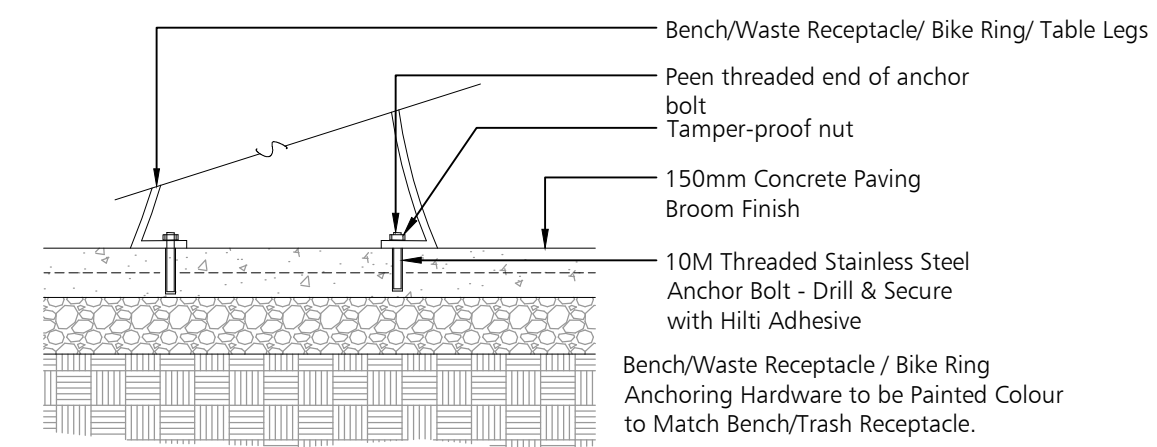

SURFACE MOUNTING
NTS



MANUFACTURER: Toronto Fabricating & Mfg Co. MOUNTING: SURFACE MOUNT. REFER TO DETAIL 3A.2

BIKE RING
NTS

1077-5
The Mississauga bench.
Style: #1077-5-6
Length: 6ft long
Other lengths available.
Ends: cast aluminum .356 alloy.
Available in grey cast iron.

Seat and back: Steel.
Optional: Space for plaque.
Names or logos can be incorporated on to frame.

Lugs with predrilled holes for surface mounting.
Hot dipped galvanized, primed and painted.
All standard RAL colours are available as well as specified custom colours.
See complimentary styles:
#7201 bench
#7201 NB-no back bench

Custom modular applications available upon request.

Note: All Drawings by Baker Turner inc. to be Printed in Colour.

REVISIONS

20 Jun 2024 Issued for 4th Round OPA/ZBL Submission
16 May 2024 Issued for Engineering Submission #1

DATE DESCRIPTION

NOTE: Contractor is to check and verify all dimensions and conditions on the project, and to immediately report any discrepancies to the landscape architect before proceeding with the work.

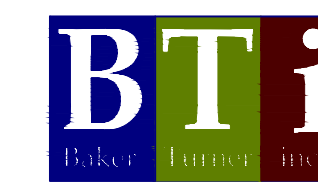

Landscape Architecture | Site Design

Suite 234
2010 Winston Park Drive
Oakville Ontario L6H 5R7
Tel: (905) 453-9398
web: bakerturner.com
email: tba@bakerturner.com

Project Title

10 WEST GO GP INC.

High Street Residential
17 & 19 Ann St., 84 & 90 High St
Mississauga ON

STREETSCAPE DETAILS

Date August 2020 Issued

Job Number B7I-1490 Drawn By EO, AS

Scale As Shown Checked By JW/TT/SB

Sheet Number SM.2 File Number OZ/OPA 22-3 W1