

GENERAL NOTES

**CRW 2 L.P., CRW 2 G.P. INC. (c/o Slate Asset Management)**

2077 & 2105 Royal Windsor drive  
Mississauga ON L5J 1K5

**Gensler**

150 King Street West  
Suite 1400  
Toronto, Ontario M5H 1J9  
Canada  
Tel 416.601.3890

LEGEND

LOCKERS AND BICYCLE PARKING SPACE DIMENSIONS

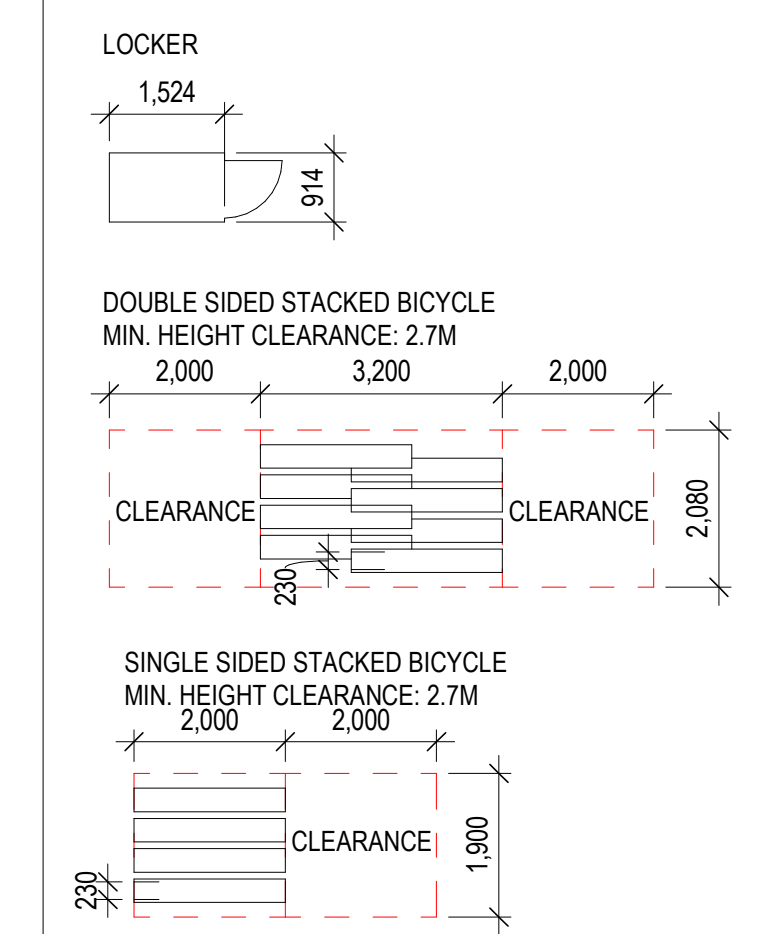

TYPICAL CAR PARKING DIMENSIONS

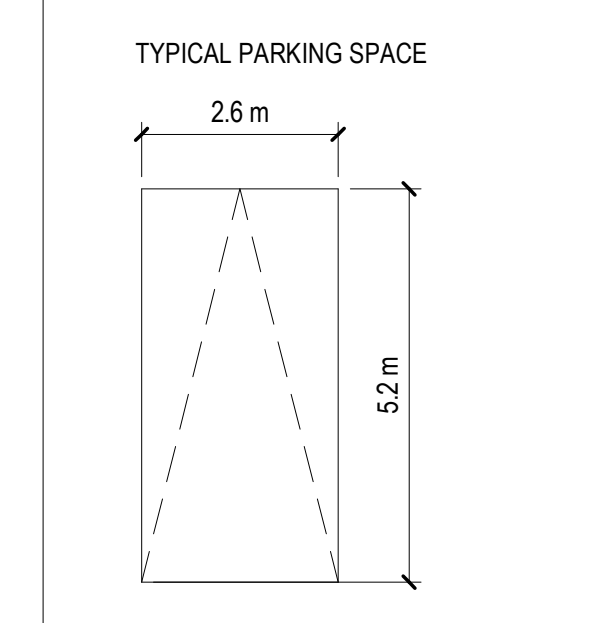

BARRIER FREE - TYPE A

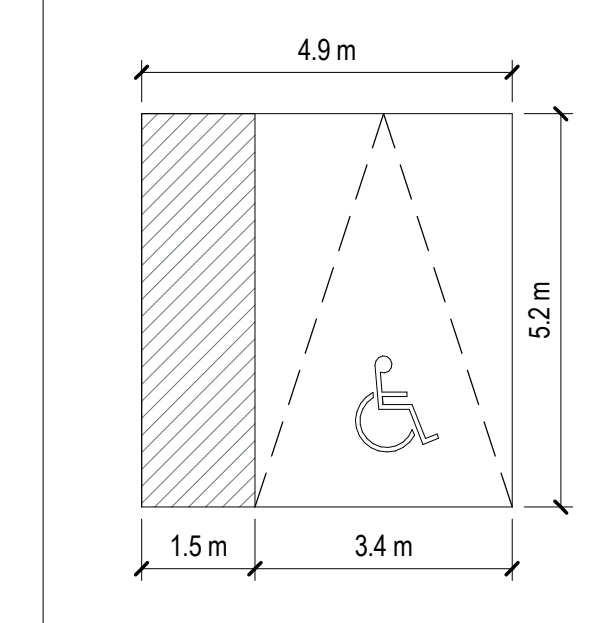

BARRIER FREE - TYPE B

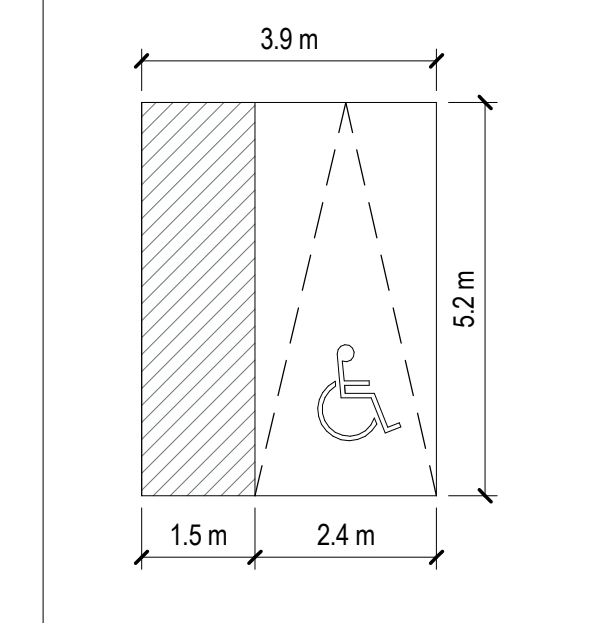

Date	Description
1 2024-09-25	OPA2BA SUBMISSION

Seal / Signature



Project Name  
**CLARKSON GO**

Project Number  
**67.1245.000**

Description  
**LOWER LEVEL - P3 TYPICAL PLAN**

Scale  
As indicated

**A1.197**



20240925 12:50:07 PM A:\architect\671245000 - Clarkson GO - E23\Architectures - E7 1245.000 - Clarkson GO - E23.rvt