

GENERAL NOTES

CRW 2 L.P., CRW 2 G.P. INC. (c/o Slate Asset Management)

2077 & 2105 Royal Windsor drive
Mississauga ON L5J 1K5

Gensler

150 King Street West
Suite 1400
Toronto, Ontario M5H 1J9
Canada

LEGEND

LOCKERS AND BICYCLE PARKING SPACE DIMENSIONS

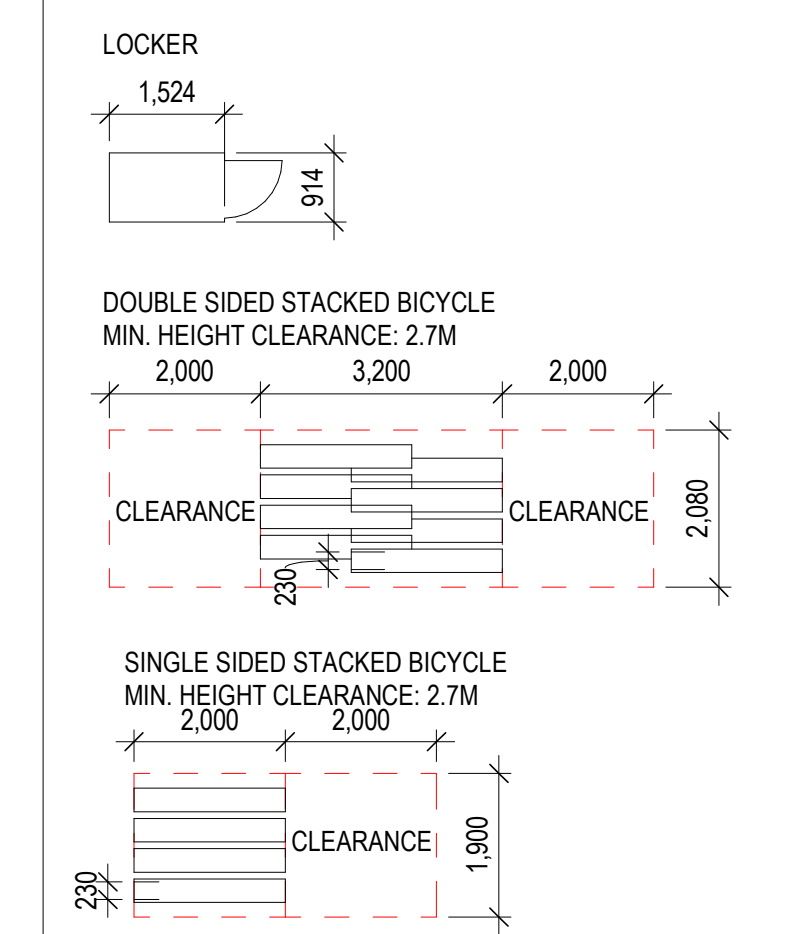

TYPICAL CAR PARKING DIMENSIONS

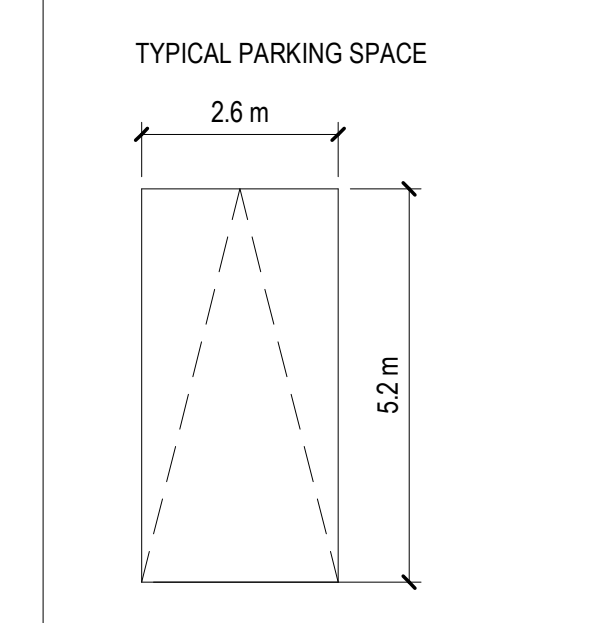

BARRIER FREE - TYPE A

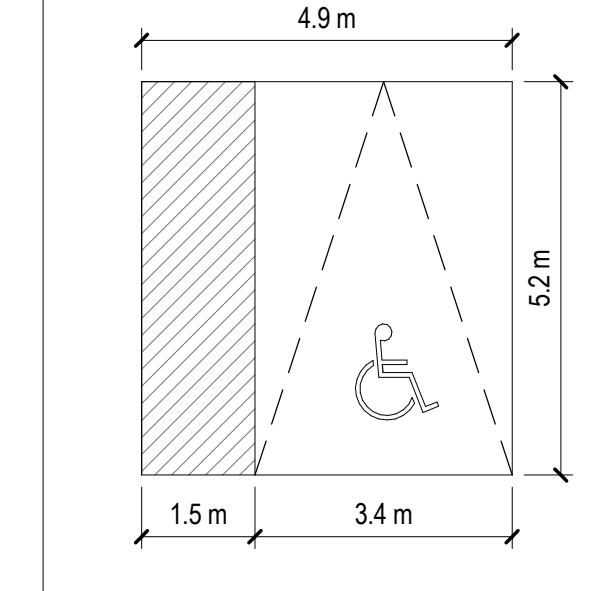

BARRIER FREE - TYPE B

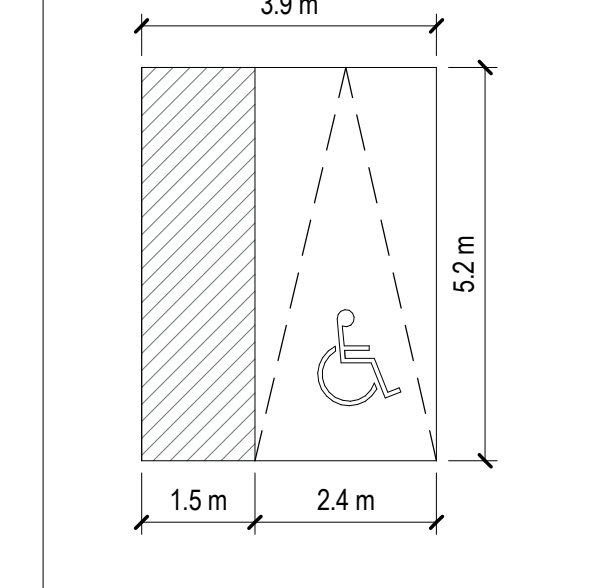

Date	Description
1 2024-09-25	OPA2BA SUBMISSION

Seal / Signature



Project Name
CLARKSON GO

Project Number
67.1245.000

Description
LOWER LEVEL - P2 TYPICAL PLAN

Scale
As indicated

A1.198