

TURNER FLEISCHER

Turner Fleischer Architects Inc.
67 Leasmill Road
Toronto, ON, M3B 2T8
T 416 425 2222
turnerfleischer.com

This drawing, as an instrument of service, is provided by and is the property of Turner Fleischer Architects Inc. The contractor must verify and accept responsibility for all dimensions and conditions on site and must notify Turner Fleischer Architects Inc. of any variations from the approved information. This drawing is not to be used for any other project. The architect is not responsible for the accuracy of survey, structural, mechanical, electrical, etc. information shown on this drawing. Refer to the appropriate consultant's drawings before proceeding with the work. Construction must conform to all applicable codes and requirements of authorities having jurisdiction. The contractor working from drawings not specifically marked "For Contractor" must assume full responsibility and bear costs for any corrections or damages resulting from his work.

TYPICAL PARKING DIMENSIONS:

AISLE WIDTH: MIN 7m

TYPICAL PARKING SPACE:
MIN 2.6 x 5.2 x 2.0m HIGH

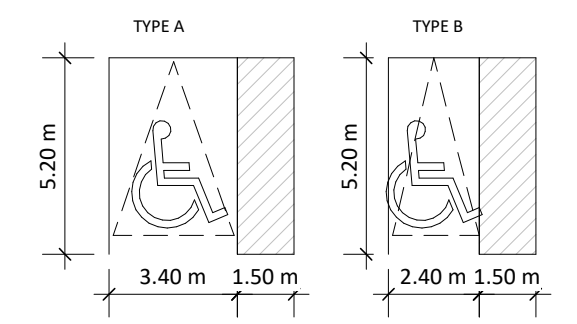
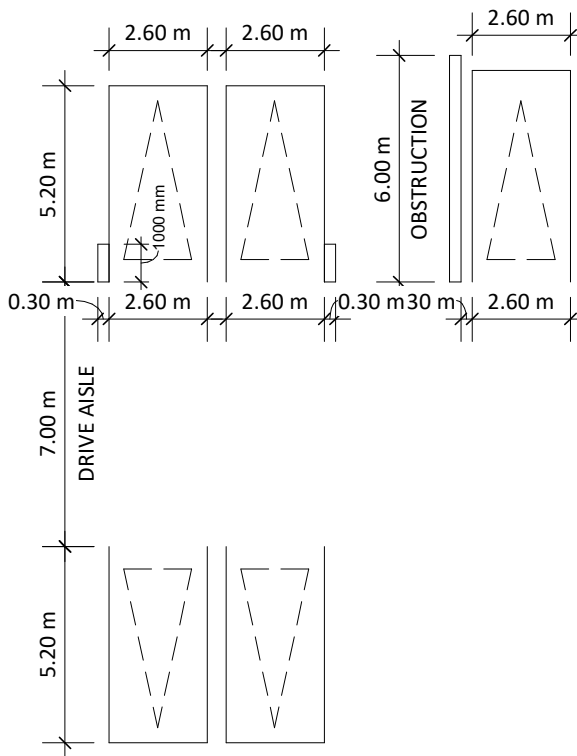

LEGEND

WALL/COLUMN-MOUNTED CONVEX MIRRORS

V VISITOR PARKING

#	DATE	DESCRIPTION	BY
4	2023-06-08	Issued for Rezoning Submission	TCH
3	2022-10-20	Issued for Rezoning	DRD
2	2022-04-22	Issued for SPA	TCH
1	2020-05-22	Issued for Rezoning Submission #1	LSV

PROJECT NO. 16.286SPA
PROJECT DATE 2018-04-20
DRAWN BY MPA
CHECKED BY RMM
SCALE 1 : 200

PROPOSED RESIDENTIAL DEVELOPMENT

Kaneff Crescent and Mississauga Valley Boulevard,
Mississauga, ON
City File NO. OZ 20/070

UNDERGROUND LEVEL 3

PROJECT NO.	PROJECT DATE	DRAWN BY	CHECKED BY	SCALE
16.286SPA	2018-04-20	MPA	RMM	1 : 200

