

This drawing, as an instrument of service, is provided by and is the property of Turner Fleischer Architects Inc. The contractor must verify and accept responsibility for all dimensions and conditions on site and must notify Turner Fleischer Architects Inc. of any variations from the approved information. This drawing is not to be used for any other project. The architect is not responsible for the accuracy of survey, structural, mechanical, electrical, etc. information shown on this drawing. Refer to the appropriate consultant's drawings before proceeding with the work. Construction must conform to all applicable codes and requirements of authorities having jurisdiction. The contractor working from drawings not specifically marked "For Contractor" must assume full responsibility and bear costs for any corrections or damages resulting from his work.

### TYPICAL PARKING DIMENSIONS:

aisle width: MIN 7m

TYPICAL PARKING SPACE:  
MIN 2.6 x 5.2 x 2.0m HIGH

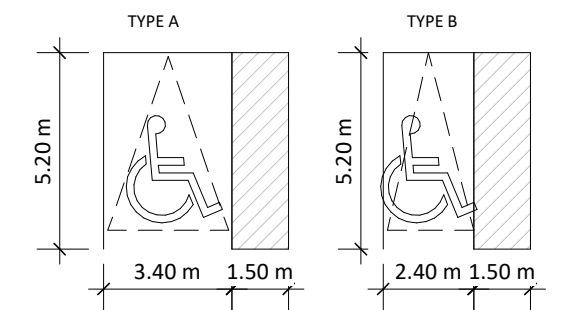
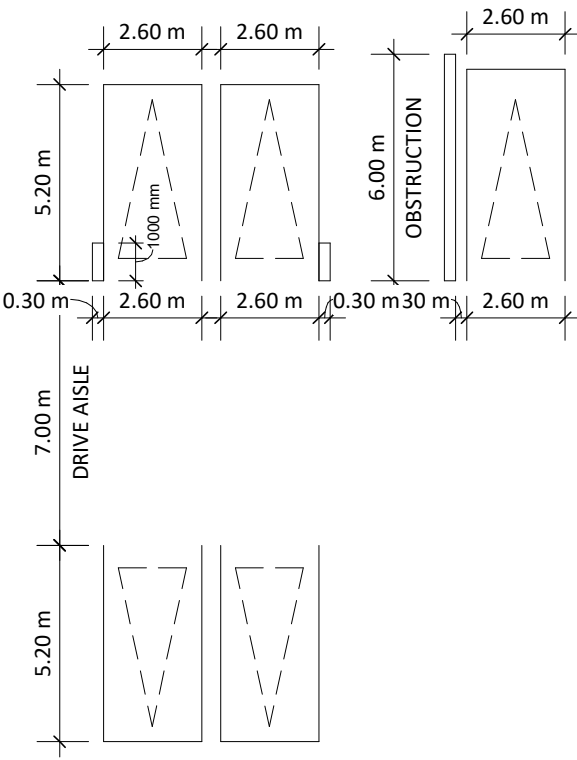

### LEGEND

- WALL/COLUMN-MOUNTED CONVEX MIRRORS
- V VISITOR PARKING

#	DATE	DESCRIPTION	BY
4	2023-06-08	Issued for Rezoning Submission	TCH
3	2022-10-20	Issued for Rezoning	DRD
2	2022-04-22	Issued for SPA	TCH
1	2020-05-22	Issued for Rezoning Submission #1	LSV

**PROPOSED RESIDENTIAL DEVELOPMENT**  
Kaneff Crescent and Mississauga Valley Boulevard,  
Mississauga, ON  
City File NO. OZ 20/070

### UNDERGROUND LEVEL 4

PROJECT NO.	16.286SPA
PROJECT DATE	2018-04-20
DRAWN BY	Author
CHECKED BY	Checker
CHECKED BY	Checker
SCALE	1 : 200

DRAWING NO.	A102	REV.	4
-------------	------	------	---

