

ISSUES

No.	DESCRIPTION	DATE
1	ISSUED FOR RE-ZONING/OPA	2020-08-31
2	ISSUED FOR RE-ZONING/OPA	2022-04-08
3	RE-ISSUE FOR ZONING/OPA	2022-08-11

PROPOSED PARKING BLDG. A

Level	Count
SURFACE PARKING	41
LEVEL P1	77
A-R	118
SURFACE PARKING	20
A-V	20
TOTAL	138

BUILDING A (127 UNITS) :
 118 RESIDENTIAL @ PROPOSED RATIO: 0.94 / UNIT
 20 VISITORS @ PROPOSED RATIO: 0.16 / UNIT

PROPOSED PARKING BLDG. B

Level	Count
SURFACE PARKING	41
LEVEL P1	76
B-R	117
SURFACE PARKING	20
B-V	20
TOTAL	137

BUILDING B (126 UNITS) :
 118 RESIDENTIAL @ PROPOSED RATIO: 0.94 / UNIT
 20 VISITORS @ PROPOSED RATIO: 0.16 / UNIT

PROPOSED PARKING BLDG. C

Level	Count
LEVEL 04	64
LEVEL 03	65
LEVEL 02	65
LEVEL 1 GROUND FLOOR	60
C-R	254
SURFACE PARKING	41
C-V	41
TOTAL	295

BUILDING C (255 UNITS) :
 252 RESIDENTIAL @ PROPOSED RATIO: 0.99 / UNIT
 41 VISITORS @ PROPOSED RATIO: 0.16 / UNIT

PROPOSED PARKING TOTAL BY LEVEL

Level	Count
LEVEL 04	64
LEVEL 03	65
LEVEL 02	65
SURFACE PARKING	163
LEVEL 1 GROUND FLOOR	60
LEVEL P1	153
TOTAL: 570	570

SITE TOTAL (508 UNITS)
 489 RESIDENTIAL @ PROPOSED RATIO: 0.96 / UNIT
 81 VISITORS @ PROPOSED RATIO: 0.16 / UNIT
 SITE TOTAL REQUIRED PARKING SPACES : 570

LEGEND - PARKING SPACE DIMENSIONS

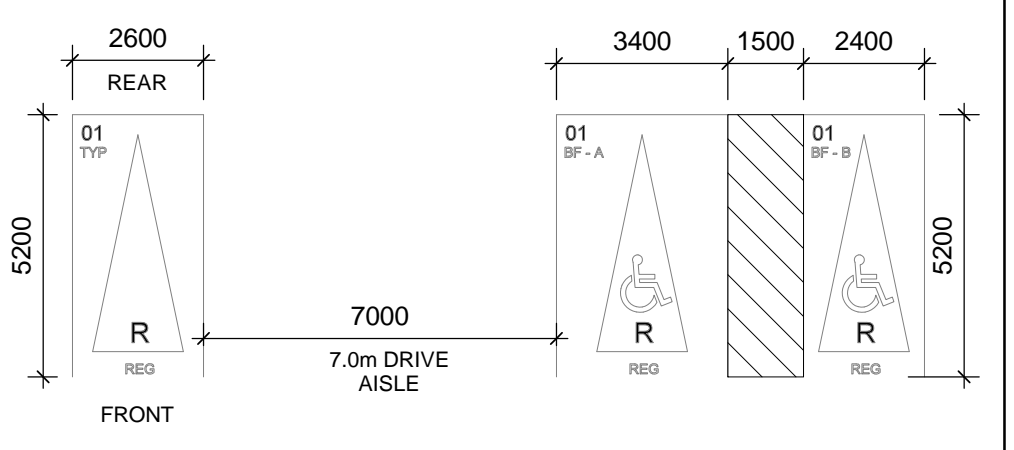

TYPICAL PARKING SPACE
 5.2m LENGTH / 2.5m WIDTH / 2.0m VERTICAL CLEARANCE

ACCESSIBLE PARKING SPACE

TYPE A
 5.2m LENGTH
 3.4m WIDTH - ADJACENT TO A 1.5m ACCESS AISLE
 2.1m VERTICAL CLEARANCE

TYPE B
 5.2m LENGTH
 2.9m WIDTH - ADJACENT TO A 1.5m ACCESS AISLE
 2.1m VERTICAL CLEARANCE

LEGEND - PARKING SYMBOLS & NOTATIONS

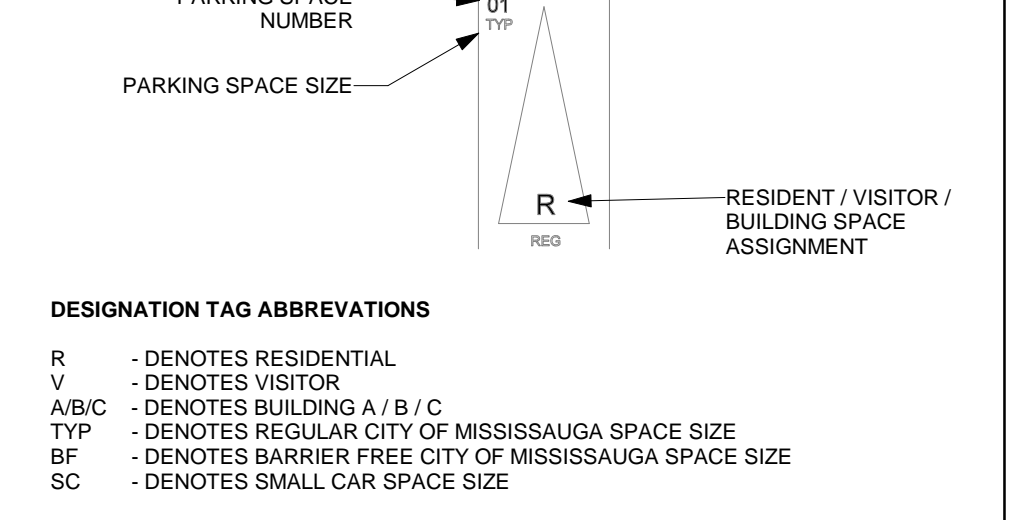

TOTAL RESIDENTIAL BIKE...

Level	Total Bike Spaces	RES LT		RES ST	
		Long Term	Short Term	Long Term	Short Term
LEVEL P1	121	121	0		
LEVEL 1 GROUND FLOOR	69	29	40		
LEVEL 02	12	12	0		
LEVEL 03	11	11	0		
LEVEL 04	9	9	0		
TOTAL BIKE SPACES	222	182	40		

BUILDING C (255 UNITS)
 176 LONG TERM BIKES @ REQUIRED RATIO: 0.7 / UNIT
 20 SHORT TERM BIKES @ REQUIRED RATIO: 0.08 / UNIT

BUILDING A+B (253 UNITS)
 20 SHORT TERM BIKES @ REQUIRED RATIO: 0.08 / UNIT

LEVEL 4 - UNIT MIX

Unit Type	Count
1B	8
2B	1
3B	2
UNIT TOTAL COUNT	11

LEVEL 4 FLOOR PLAN
 Scale: 1 : 150

